

Stuttgarter Beiträge zur Naturkunde

Serie A (Biologie)

Herausgeber:

Staatliches Museum für Naturkunde, Rosenstein 1, D-70191 Stuttgart

Stuttgarter Beitr. Naturk.	Ser. A	Nr. 678	15 S., 3 Abb., 5 Tab.	Stuttgart, 10. V. 2005
----------------------------	--------	---------	-----------------------	------------------------

Genetic variability in European sculpin, *Cottus gobio* (Pisces: Cottidae): Assignment of population samples from the Brenta (Italy) and the Sava (Slovenia) river systems to Central European population groups

LAURA PAPA & ARND SCHREIBER

Abstract

Based on allozyme genetics, European sculpins or bullheads (*Cottus gobio* Linnaeus, 1758) from the Brenta River system (Adriatic basin, north east Italy) cluster with population samples collected in the middle Danube catchment (Sava, Slovenia) and the Danubian headwaters, and with sculpins from the Lake Constance, but are more deeply differentiated from sculpins collected in the Neckar (Rhine) and the Doubs (Rhône) river systems. The weak genetic distance among populations from the middle Danube and the unconnected Brenta system of the Adriatic basin supports the notion of a comparatively recent Danubian origin for the occurrence of sculpins in the Padano-Venetian fish community. The steep genetic gradient that separates the sculpins from the Danube and the Neckar in south west Germany (RIFFEL & SCHREIBER 1995, 1998) might therefore have originated by the secondary population contact of pre-diverged stocks, rather than by evolution *in situ* of a species that is likely to be an inefficient disperser. The validity of the controversial taxon *Cottus [gobio] ferrugineus* from peri-Adriatic drainages is discussed.

Key words: Sculpin, *Cottus*, allozyme variability, biogeography, taxonomy.

Zusammenfassung

Mühlkoppen (*Cottus gobio* Linnaeus, 1758) aus dem Einzugsgebiet der Brenta (Adria-zufluss, NO Italien) unterscheiden sich populationsgenetisch (Isoenzyme) geringfügiger von Stichproben aus dem mittleren (Sava, Slowenien) oder dem oberen Donauesystem (Oberschwaben) als von solchen aus den Einzugsgebieten von Neckar (Rhein) oder Doubs (Rhône). Der enge genetische Zusammenhang von Mühlkoppen aus der adriatischen Brenta und dem Donaubecken passt zur arealgeographischen Ableitung der Padano-Venetischen Region der italienischen Fischfaunistik von der danubischen Fauna. Der steile genetische Gradient zwischen Groppenbeständen der oberen Donau und des Neckars (RIFFEL & SCHREIBER 1995, 1998) erweist sich durch diese Befunde als die Folge eines sekundären Populationskontaktes von zwei Einwandererlinien, während die vorher ebenfalls für möglich gehaltene primäre genetische Divergenz in einer Fischart mit vermutlich geringer Fähigkeit zur raumgreifenden Dismigration nicht länger wahrscheinlich ist. Einige Schlussfolgerungen zur Validität des italienischen Taxons *Cottus [gobio] ferrugineus* werden gezogen.

Contents

1	Introduction	2
2	Material and methods	4
	2.1 Populations	4
	2.2 Techniques and statistics	5
3	Results	6
4	Discussion	10
5	References	13

1 Introduction

The common sculpin or river bullhead (*Cottus gobio* Linnaeus, 1758) is a bottom-dwelling fish from cool, oxygen-rich running or stagnant fresh waters. It ranges throughout the European continent, being absent only from the Arctic and the Mediterranean climate zones (BERG 1932, BANARESCU 1992). THIENEMANN (1941, 1950) rated *Cottus gobio* as a member of his zoogeographical category of the "glacial mixed fauna". This category comprises fish species that are sufficiently adapted to cold waters to have survived the glacial periods of the Pleistocene in water bodies located between the Scandinavian and the Alpine inland glaciations. Therefore populations may have persisted in the non-glaciated parts of mainland Europe since pre-Quaternary times, from where they have colonized intermittently glaciated or periglacial areas whenever biotopes had reappeared. Maximum movements of tagged sculpins observed in streams of the Harzvorland (Germany) measured 800 m of stream length or less (STAHLBERG-MEINHARDT 1994); DOWNHOWER et al. (1990) reported even more restricted movement. Vertical precipices in a river above a height of 20 cm seem to impede upstream movement sufficiently (SMYLY 1957, BARANDUN 1990, BLESS 1990). A seemingly resident species that, in addition, has not been translocated or stocked for fisheries interests or pisciculture on any noteworthy scale might serve as an appropriate indicator for the study of the geographic range and the colonization history of European catchments by freshwater fishes.

A couple of investigations have confirmed a localized or regionalized, but in any case a mosaic-like distribution pattern of morphometric, meristic or anatomical characters in sculpin populations at the geographical scale of single rivers, or in parts of catchments (BĂCESCU & BĂCESCU-MESTER 1964, SKOŘEPA 1966, KOLI 1969, WITKOWSKI 1979). The allozyme and morphometric investigations by RIFFEL & SCHREIBER (1995, 1998) demonstrated a deep genetic subdivision of *Cottus gobio* populations in the region where the Rhine, the Danube, and the Rhône catchments meet: The allele frequency distance across the Neckar/Danube watershed approached or exceeded distance values that distinguish certain species of *Cottus* from within the eastern Palaearctic or the Nearctic regions (RIFFEL & SCHREIBER 1995). A genetic transition zone in the southern Rhine system connected these distinctive populations. This zoogeographical pattern was interpreted as having resulted either from evolution *in situ* of deep lineages in a rather stationary species, which is among the most ancient faunal elements in the fish fauna of the study area (TORKE 1998), or from the secondary population contact of sculpins that had immigrated into the study area after the evolution of genetic differences in isolation, and which have hybridized. A comparable coarse-grained population structure with deep and previously cryptic lineages was subsequently confirmed by the allozyme studies by

HÄNFLING (1997) and HÄNFLING & BRANDL (1998) for *Cottus gobio* from the adjacent watershed area of the Rhine, the Danube, and the Elbe, by EPPE et al. (1999) for southern France, by the mtDNA analysis of ENGLBRECHT et al. (2000) and VOLCKAERT et al. (2002), the DNA-microsatellite study of HÄNFLING et al. (2002) for several European drainages, and by the allozyme, mtDNA and morphometric investigations by KONTULA & VÄINÖLÄ (2001, 2004) and KONTULA (2003) for the eastern Scandinavian peninsula. PAŠKO & MAŠLAK (2003) confirmed a comparable genetic population pattern for *Cottus poecilopus* from catchments in Poland. These authors interpreted the considerably different allele frequencies between regional sculpin populations as the result of historical range dynamics, and some authors implied the expansion of genetically diverged sculpin stocks from different core populations in Pleistocene refuges. According to HÄNFLING et al. (2002) there might have been several such Pleistocene refuges, as predicted by THIENEMANN (1941, 1950).

In the Apennine peninsula sculpins inhabit both Adriatic and some of the Tyrrhenian catchments from the Alps southwards to the Nera River in Umbria, central Italy (GANDOLFI et al. 1991). Bullheads from Italy have been classified as an endemic species, *Cottus ferrugineus* (Heckel & Kner, 1858) or as a subspecies, *C. gobio ferrugineus*, whose validity has been discussed controversially (BĂCESCU & BĂCESCU-MESTER 1964, KOLI 1969, KOTTELAT 1997). The relationship of *ferrugineus*-sculpins, living at the southern periphery of the range of *Cottus gobio*, to the population groups identified by RIFFEL & SCHREIBER (1995) from south Central Europe remains unknown. Assuming an isolating effect of the high-altitude watersheds in the Alps, the Italian Peninsula is generally not considered to be an important Pleistocene refuge for freshwater fishes, and presumably Italy has not exported many species for the postglacial colonization of more northerly European rivers (BANARESCU 1992). On the other hand, BIANCO (1995a, b) proposed that the Danube river system had delivered most species of cold-stenothermous fishes into the drainages around the Adriatic Sea, of which some were able to expand their range further across the Adriatic-Tyrrhenian watershed.

The present study compares the allozyme genetics of European sculpins collected in the Brenta River system, Italy, with previously genotyped population samples that originated from north of the Alps, i. e. in the southern Rhine, the upper Rhône, and the upper Danube catchments, and with sculpins from the Sava drainage system (Slovenia), which represents a more south easterly location in the middle Danube region. The study contributes to clarify the genetic status of the controversial taxon *Cottus gobio ferrugineus*, and to test published hypotheses about a putatively Danubian origin of that possibly endemic fish or for that matter of the temperate and cold-stenothermous guild of fishes from Padano-Venetian province of fish faunistics that comprises the Brenta River (BIANCO 1995a).

Acknowledgments

Our collection of sculpins for this study was kindly supported by various colleagues: Dr. ENRICO MARCONATO (Vicenza, Italy), Prof. Dr. JASNA STRUŠ and MARKO BERTOK (University of Ljubljana, Slovenia), and RALF HABERBOSCH (Fischereiforschungsstelle Langenargen, Germany). The fisheries authorities of the Bezirksregierung Karlsruhe (Baden-Württemberg, Germany) supported this study.

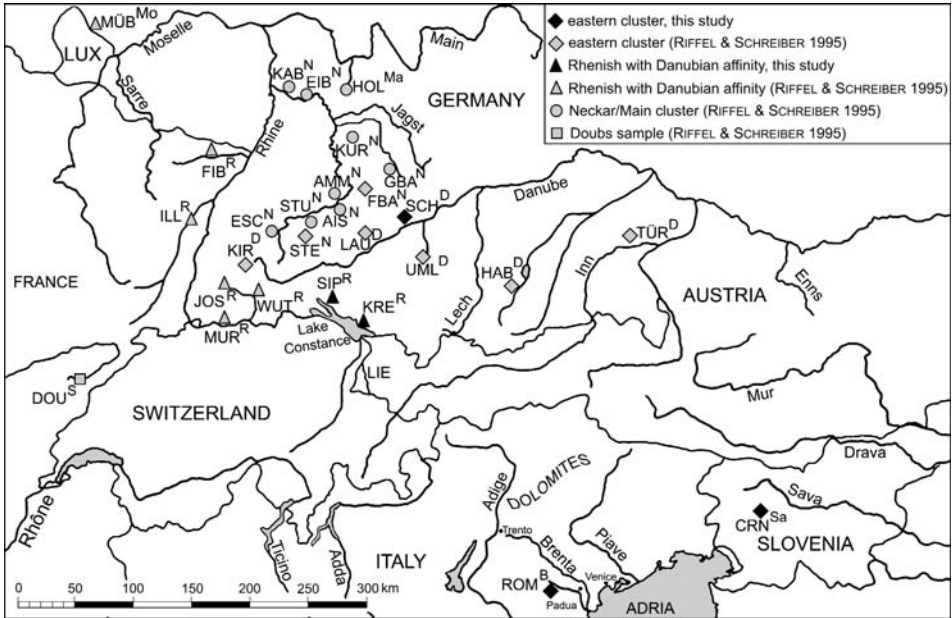

Fig. 1. Collection sites of river bullheads (*Cottus gobio*) for allozyme analysis. Black symbols denote samples analysed in this study, and grey-shaded ones the reference samples from RIFFEL & SCHREIBER (1995). – Abbreviations of the localities: **Neckar:** KAB^N = Katzenbach; EIB^N = Eiterbach; GBA^N = Gruppenbach; FBA^N = Fischbach; KUR^N = Kurzbach; AMM^N = Ammer; STU^N = Stunzach; STE^N = Steinlach; ESC^N = Eschach; AIS^N = Aischbach. **Other Rhenish sites:** MÜB^{Mo} = Mühlbach; HOL^{Ma} = Hollerbach; FIB^R = Fischbaechele; ILL^R = Ill; MUR^R = Murg; WUT^R = Wutach; JOS^R = Josbach; SIP^R = Sipplingen; KRE^R = Kressbronn. **Danube:** KIR^D = Kirnach; LAU^D = Lauchert; SCH^D = Schmiech; UML^D = Umlach; HAB^D = Hardtbach; TÜR^D = Türkenbach; CRN^{Sa} = Érna (Sava). **Rhône (Saône):** DOU^S. **Brenta:** ROM^B = Roggia Menegatta.

2 Material and methods

2.1 Populations

Population samples were collected by electroshocking at five sites in Italy, Slovenia and Germany (Tab. 1, Fig. 1), in the years 2002 and 2003. The tissue bank collected in 1992–1995 (RIFFEL & SCHREIBER 1995) and since (A. SCHREIBER, unpublished data) supplied reference samples. Roggia Menegatta (ROM^B), located in the Vicenza Province (Veneto, north east Italy), is a minor affluent of the Bacchiglione, which is a tributary of the Brenta River. The Brenta enters the Adriatic Sea in the Chioggia Province (Veneto) south of the Venetian lagoon. At the collection site the riverbed sediments were composed of 65 % silt, 30 % sand, and 5 % gravel. *Ceratophyllum* dominated the abundant macrophyte vegetation, but *Callitriche*, *Potamogeton* and *Ranunculus* were also common. Apart from bullheads the local fish fauna included three-spined stickleback *Gasterosteus aculeatus* (Linnaeus, 1758), minnow *Phoxinus phoxinus* (Linnaeus, 1758), the goby *Padogobius martensi* (Günther, 1861), and occasionally stocked pike *Esox lucius* (Linnaeus, 1758). The Crna (CRN^{Sa}) is a tributary of the river Kamniska Bistrica near the city of Kamnik (Slove-

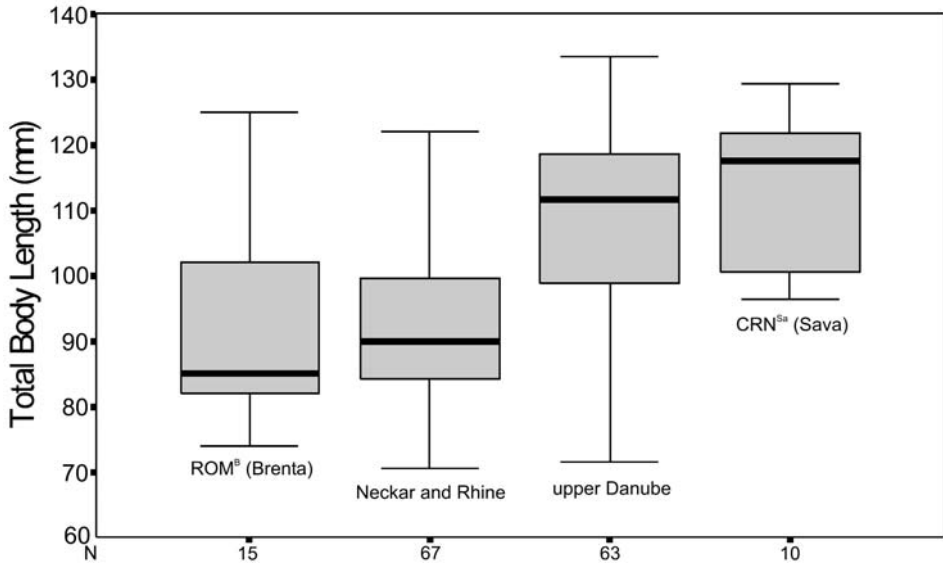

Fig. 2. Standard body lengths (mm) of four geographical samples of the European sculpin (*Cottus gobio*) comprising both males and females each. The thick bars indicate the data medians, the boxes the range between the 25 % and the 75 % percentiles, and the bars span the range of deviant specimens. For the samples from south west Germany see RIFFEL & SCHREIBER (1998).

nia). In the Lake Constance sculpins were collected at the shore off Kressbronn (KRE^R) and Sipplingen (SIP^R). The Schmiech (SCH^D) sample originated from Ehingen. There is no indication that sculpins have ever been stocked at these sites. Fig. 2 and Tab. 2 provide some data on the studied sculpins for reference and characterization.

2.2 Techniques and statistics

Freshly dissected tissue samples from skeletal muscle and liver were stored at -70°C . Then the lysates, prepared by sonication, were applied to a 1-mm-thick horizontal agarose gel for electrophoresis. The buffer systems and the zymography pro-

Tab. 1. Collection sites of bullheads (*Cottus gobio*) for allozyme analysis. These population samples are compared to the data matrix described by RIFFEL & SCHREIBER (1995). – n = sample size; * = sample by RIFFEL & SCHREIBER (1995).

Collection site	Catchment	n
Roggia Menegatta (ROM ^B)	Brenta	15
Érna (CRN ^{Sa})	Sava / middle Danube	10
Schmiech (SCH ^D)	upper Danube	7 (+26*)
Kressbronn (KRE ^R)	Lake Constance / Rhine	22
Sipplingen (SIP ^R)	Lake Constance / Rhine	11

Tab. 2. Average fin ray numbers of population samples of the European sculpin (*Cottus gobio*). –¹ = Collectives characterized by RIFFEL & SCHREIBER (1998).

Catchment	1 st dorsal fin	2 nd dorsal fin	anal fin
Brenta	5.93 ± 0.59	16.46 ± 0.64	10.46 ± 1.06
Sava/middle Danube	7.30 ± 0.48	16.60 ± 0.52	13.80 ± 0.42
Doubs ¹	7.90 ± 0.60	16.40 ± 0.87	13.00 ± 0.39
Neckar ¹	7.00 ± 0.56	17.20 ± 0.81	13.00 ± 0.70
Upper Danube ¹	6.50 ± 0.70	16.00 ± 0.60	12.00 ± 0.67

protocols are those referred to by RIFFEL & SCHREIBER (1995). The nomenclature of loci and alleles follows SHAKLEE et al. (1990). Calculation of Nei's standard genetic distances (Phylip/Gendist), of neighbour-joining (Phylip/Neighbor), of half-delete jack-knifing (Phylip/Seqboot) and of consensus tree building (Phylip/Consense) utilized the Phylogeny Inference Programme Package (J. FELSENSTEIN, University of Washington, Seattle, U.S.A.).

3 Results

Seventeen allozyme loci, including ten polymorphic ones, have been screened in 65 European sculpins sampled from five collection sites in Italy, Slovenia, and Germany (Tab. 1). These data were evaluated in combination with a previous database that rested on 261 specimens from south west Central Europe (RIFFEL & SCHREIBER 1995). The following enzymes and loci found polymorphic in a previous research of RIFFEL & SCHREIBER (1995) were considered: Acid phosphatase (*Acp-2**), aconitate hydratase (*Ab**), aspartate aminotransferase (*Aat-1**, *Aat-2**), esterase (*Est-1**, *Est-2**), fumarate hydratase (*Fb**), glucose phosphate isomerase (*Gpi-1**, *Gpi-2**), glycerol-3-phosphate-dehydrogenase (*G3pdh-1**), isocitrate dehydrogenase (*Idhp-1**, *Idhp-2**), malate dehydrogenase (*Mdh-1**, *Mdh-2**), 6-phosphogluconate dehydrogenase (*Pgdh-1**), phosphoglucomutase (*Pgm-1**), and an unspecific dehydrogenase (*Udh**). This study did not identify major new alleles, in addition to those described previously for population samples collected in Central Europe (RIFFEL & SCHREIBER 1995), except for the marker *Gpi-1*120* that proved diagnostic for every sculpin from CRN^{Sa}. *Gpi-2*80* and *Gpi-1*130* appeared as previously undescribed alleles of very limited occurrence. Tab. 3 provides the allele frequencies and the heterozygosity estimates for the population samples.

A review of all allozymes hitherto described by our group (Tab. 4) reveals a couple of private alleles confined to population samples from a single stream: *Gpi-1*130* (ROM^B) in the Brenta, *Gpi-1*120* (CRN^{Sa}) in the Sava, *Aat-2** (GBAN^N) in the Neckar, *Gpi-2*120* (JOS^R) in the southern Rhine, and *Idh-1*85* (UML^D) and *Idh-2*125* (SCH^D) in the upper Danube. Of these, only *Gpi-1*120* appeared to have reached complete fixation in the sample from the Sava catchment for which it seemed to be exclusive, but the other private markers were found as variants in polymorphism together with geographically more widespread alleles. Of higher interest for zoogeographical inference are alleles that have reached complete fixation in larg-

Tab. 3. Frequencies of enzyme alleles in population samples of river bullheads (*Cottus gobio*), including the polymorph loci identified in the present study and those found by RIFFEL & SCHREIBER (1995). For the nomenclature of loci and alleles compare RIFFEL & SCHREIBER (1995).

Locus	Allele	SIP ^R	KRE ^R	SCH ^D	ROM ^B	CRN ^{Sa}
<i>Aat-2</i> *	100	1.000	1.000	1.000	1.000	1.000
	120	0.000	0.000	0.000	0.000	0.000
<i>Ab</i> *	92	0.000	0.000	0.000	0.000	0.000
	100	1.000	1.000	1.000	1.000	1.000
<i>Idb-1</i> *	85	0.000	0.000	0.000	0.000	0.000
	100	1.000	1.000	1.000	1.000	1.000
<i>Idb-2</i> *	100	1.000	1.000	1.000	1.000	1.000
	125	0.000	0.000	0.000	0.000	0.000
<i>Pgm-1</i> *	58	0.000	0.000	0.000	0.000	0.000
	78	0.000	0.000	0.000	0.000	0.000
	100	1.000	1.000	0.860	1.000	1.000
	130	0.000	0.000	0.140	0.000	0.000
<i>Gpi-1</i> *	100	1.000	1.000	1.000	0.930	0.000
	120	0.000	0.000	0.000	0.000	1.000
	130	0.000	0.000	0.000	0.070	0.000
<i>Gpi-2</i> *	80	0.000	0.050	0.000	0.000	0.000
	100	0.050	0.090	0.000	1.000	1.000
	120	0.950	0.860	1.000	0.000	0.000
<i>Est-1</i> *	88	0.000	0.045	0.780	0.000	0.000
	100	1.000	0.955	0.220	0.500	0.000
	120	0.000	0.000	0.000	0.500	1.000
<i>Fn</i> *	100	1.000	1.000	1.000	1.000	1.000
	120	0.000	0.000	0.000	0.000	0.000
	150	0.000	0.000	0.000	0.000	0.000
<i>Acp-2</i> *	100	1.000	1.000	1.000	0.930	1.000
	130	0.000	0.000	0.000	0.070	0.000
<i>Pgdb</i> *	100	1.000	1.000	1.000	1.000	1.000
	105	0.000	0.000	0.000	0.000	0.000
<i>Udb</i> *	-34	0.000	0.000	0.000	0.000	0.000
	-100	1.000	1.000	1.000	1.000	1.000
<i>n</i>		11	22	7	15	10
<i>H_o</i>		0.005	0.019	0.042	0.084	0.000

er population groups, or which are confined to a partial selection of geographical origins. Tab. 4 tabulates the geographical distribution of these sets of alleles. Brenta sculpins share most markers with every other population sample, but certain less widespread markers are shared exclusively with samples from either the Sava or from the Doubs catchments respectively.

Tab. 4. Occurrence of protein alleles that appear to be specific for certain geographical population groups of the bullhead (*Cottus gobio*). Geographical markers are printed in bold type, both if occurring as a variant in a polymorph system, or being fixed marker for the whole sample (cf. Tab. 3 and RIFFEL & SCHREIBER 1995). Private alleles exclusive for one population group are denoted by ***, and alleles shared by two population groups by **.

	ROM ^B	CRN ^{Sa}	upper Danube	Neckar/Rhine	Doubs
<i>Aat-2</i> *	100	100	100	100	100, 120***
<i>Acp-2</i> *	100, 130**	100	100	100	100, 130**
<i>Ab</i> *	100	100	100	100	92***
<i>Idh-1</i> *	100	100	85***, 100	100	100
<i>Idh-2</i> *	100	100	100, 125**	100	100
<i>Pgm-1</i> *	100	100	100, 130**	100, 130**, 78**	58***, 78**
<i>Gpi-1</i> *	100, 130***	120***	100	100	100
<i>Gpi-2</i> *	100	100	80***, 100, 120***	100	100
<i>Est-1</i> **	100, 120**	120**	88**, 100	88**, 100	100, 120**
<i>Fb</i> *	100	100	100	120***, 150***	100
<i>Pgdb</i> *	100	100	100	100, 105**	105**
<i>Udh</i> *	-100	-100	-34**, -100	-34**, -100	-100

A neighbour-joining analysis (Fig. 3), based on Nei's standard genetic distances (Tab. 5) of allele frequencies (Tab. 3), reveals a sister-group relationship of the samples from the Brenta (ROM^B) and the Sava (CRN^{Sa}), both clustering within a more comprehensive south eastern grouping that also comprises the population samples from the upper Danube drainage basin in Germany (UML^D, SCH^D), from the Lake Constance (KRE^R, SIP^R) in the Rhine catchment, and others from the southern Rhine or the Neckar systems (JOS^R, FIB^R, FBAN^N) thought to have been introgressed by Danubian sculpins in the recent past, as discussed by RIFFEL & SCHREIBER (1995). Bullheads from the study area reveal a threefold subdivision into (i) a relatively distinctive northern Neckar/Main cluster in the Rhine catchment, (ii) a sample from the upper Rhône system, and (iii) a hydrogeographically heterogeneous cluster that comprises sculpins from the southern Rhine (southern Oberrhein and Hochrhein), the FBAN^N stream (thought have been diverged from the Danube to the Neckar by a case of recent river capture), the upper and the middle Danube drainage, and the Brenta. This threefold clustering emerged as being moderately robust after one hundred runs of half-delete jack-knifing, but clearly more so than did the affiliations within these three major groupings. The genetic distance values between population samples from the Brenta and the Sava systems to their Danubian relatives in south west Germany fall short of the genetic distinction of any one population sample from this geographically widespread south eastern cluster to those of the Neckar/Main cluster or the Doubs (Rhône).

The standard body lengths of our specimens from the Brenta system were significantly smaller than of population samples from the upper Danube in Germany (Mann-Whitney test; $p < 0.001$) and from the Sava ($p < 0.001$), but they did not prove smaller than Rhenish and Neckarian sculpins (Fig. 2). The body length of Sava sculpins was not significantly different from the body size of upper Danubian

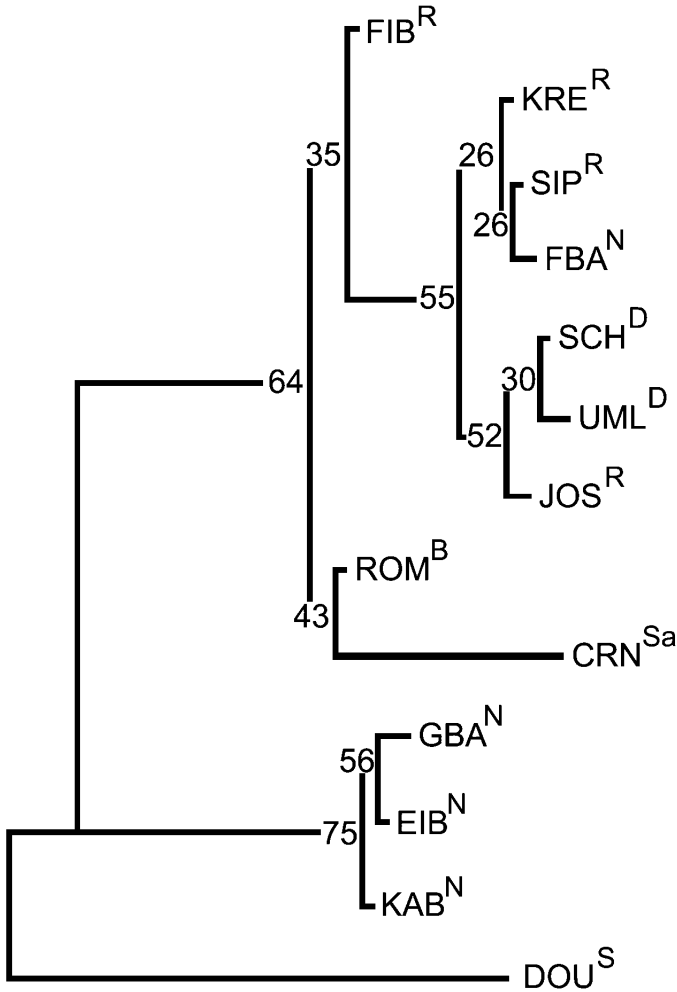

Fig. 3. Neighbour-joining tree of Nei's genetic distances among pairs of population samples of the European sculpin (*Cottus gobio*). This consensus tree integrates 100 runs of half-delete jack-knifing of the underlying allele frequencies. The numbers indicate the percentage values of confirmation for each node. DOU^S represents the defined outgroup.

samples, but both regional stocks from the Danube catchment had longer bodies than Rhenish sculpins ($p < 0.0001$). The numbers of anal fin rays (Tab. 2) averaged at 10.46 in sculpins from the Brenta system, compared with 13.80 in sculpins from Sava/middle Danube, 13.00 for samples from the Neckar, 12.10 for ones from the upper Danube (Germany), and 13.00 for the Doubs (Rhône) population (RIFFEL & SCHREIBER 1995).

Tab. 5. Nei's genetic distances between pairs of 13 population samples of European sculpins (*Cottus gobio*), based on the allele frequencies at 17 enzyme-coding loci. – Abbreviations of population samples see Fig. 1.

SCH ^D																			
ROM ^B	0.0962																		
CRN ^{Sa}	0.1867	0.0740																	
SIP ^R	0.0385	0.0725	0.1878																
KRE ^R	0.0353	0.0642	0.1778	0.0005															
JOS ^R	0.0222	0.0449	0.1305	0.0604	0.0523														
FBA ^N	0.0400	0.0910	0.2087	0.0102	0.0111	0.0717													
GBA ^N	0.3293	0.2315	0.3657	0.2758	0.2691	0.2800	0.2703												
EIB ^N	0.3172	0.2200	0.3534	0.2642	0.2574	0.2681	0.2537	0.0070											
KAB ^N	0.3127	0.2181	0.3483	0.2616	0.2548	0.2649	0.2667	0.0060	0.0112										
UML ^D	0.0046	0.1130	0.1959	0.0618	0.0575	0.0227	0.0676	0.3688	0.3565	0.3512									
FIB ^R	0.1024	0.0155	0.1252	0.0547	0.0478	0.0535	0.0730	0.2060	0.1948	0.1942	0.1264								
DOU ^S	0.3928	0.2640	0.3379	0.3936	0.3834	0.3370	0.3995	0.3256	0.3135	0.3092	0.4166	0.3154							

4 Discussion

Cottus gobio is an ancient element of the European fish fauna whose presence can be traced into pre-Pleistocene times (THIENEMANN 1950, BĂCESCU & BĂCESCU-MESTER 1964, BIANCO 1995b, KONTULA & VÄINÖLÄ 2001 and 2004), and which has persisted in south west Germany at least during the latter period of the Würm glaciation period (TORKE 1998). Sculpins are believed to have fairly limited means of dispersal and migration (STAHLBERG-MEINHARDT 1994), and even minor cataraacts or weirs are known to impede the upstream passage in a stream (SMYLY 1957, BARANDUN 1990, BLESS 1990). RIFFEL & SCHREIBER (1995, 1998) suggested that the rugged, deeply subdivided genetic architecture of the sculpin that is obvious from allozymes and morphometry could partly be explained by evolution *in situ* of regional populations that are connected by limited gene flow. As an additional explanation, the abrupt contact of genetically diverged populations observed in south west Germany could reflect the secondary range contact of stocks that had immigrated and hybridized. One of these strata was confined, in our database from Central Europe, to the Doubs (Rhône system), the second to streams in the Neckar and the Main basins (Rhine system), and the third to the southern Rhine and the upper Danube catchments (RIFFEL & SCHREIBER 1995, 1998). It is this latter, eastern population group that includes the geographically distant samples from the Sava and the Brenta River systems. Various studies have confirmed a coarse-grained genetic population structure of sculpins (HÄNFLING 1997, HÄNFLING & BRANDL 1998, EPPE et al. 1999, ENGLBRECHT et al. 2000, HÄNFLING et al. 2002, VOLCKAERT et al. 2002, KONTULA & VÄINÖLÄ 2001 and 2004). ENGLBRECHT et al. (2000) investigated DNA-sequence haplotypes of the mitochondrial control region in single specimens from many drainages in south east and Central Europe. One of their haplotype-defined population groups comprised four specimens from the spring of the Timavo River in north east Italy, those from the lower Danube drainage, and those from south east Germany. So far there is a congruence of conclusions based on mtDNA evidence (ENGLBRECHT et al. 2000) and our allozyme data that rest on a broader sample base. This

observation seems to confirm that the steep genetic gradient in south west Germany has resulted from a case of secondary population contact (RIFFEL & SCHREIBER 1995, 1998). The mosaic of genetically intermediate populations in the southern Rhine system therefore most likely reflect a hybrid belt, even though the heterozygosity of sculpin samples from that area is not elevated (RIFFEL & SCHREIBER 1995). One is led to conclude that the inferred hybridization event occurred sufficiently early, so that the genetic drift by relative inbreeding in philopatric stocks could erode the variance of a recent hybrid stock. KOLI (1969) and KONTULA & VÄINÖLÄ (2004), described a secondary contact zone for sculpins in Finland, where molecular and/or morphometric characters showed discordant spatial distribution.

The close affiliation of sculpins from the Brenta and the Sava catchments might indicate fairly recent genetic exchange between the Danube and the Brenta. The lowered sea levels during the Pleistocene glaciation phases up to 100–130 m had repeatedly extended the current Po River system on to the continental shelf that now underlies the northern Adriatic Sea (BIANCO 1994). As recently as 18.000 years before present, each affluent of the northern Adria southward to the rivers of Vomano (Italian coast) and Krka (Dalmatian coast) had coalesced into a Pleistocene “mega-Po” catchment. The common watershed of this fossil north-Adriatic catchment to the Danube basin might have extended from the Swiss Alps (Inn valley) to central Dalmatia. The Pleistocene greater-Po-system matches the Padano-Venetian district of contemporary fish faunistics (BIANCO 1990, 1995b). This district contains several endemic fish taxa or otherwise fishes with a close zoogeographical affiliation to the Danube (BANARESCU 1992, BIANCO 1990 and 1995b). BIANCO (1990, 1995b) inferred from the contemporary distribution ranges that at least the cold-stenothermous members of this Padano-Venetian fish fauna had immigrated from a Danubian origin in the Pleistocene. This view suits the independent biogeographical conclusions derived from allozymes.

In this context the taxonomic status of *Cottus ferrugineus* deserves attention. Based on a previous description by BONAPARTE (1846), this species was formally described by HECKEL & KNER (1858) from specimens collected at the Italian stations of Lago di Garda, Milano, and Treviso, and from Xegar in Croatia (KOTTELAT 1997). The species diagnosis was based on a stocky body, shorter head, a thick and compressed caudal peduncle, an elongated anal fin, and a small pectoral fin (HECKEL & KNER 1858). Many taxa discussed in their monograph show that the species concept by HECKEL & KNER (1858) differs from current fish systematics, e. g. their newly described *Cottus ferrugineus* was said to originate from the same area near Milano like sculpins thought to represent the typical *Cottus gobio*. However, the sympatric occurrence of two morphotypes of bullheads has never been confirmed (KOTTELAT 1997). BĂCESCU & BĂCESCU-MESTER (1964) accepted species status for *C. ferrugineus*, and BANARESCU (1963) subspecies status as *C. gobio ferrugineus*. OLIVA & HENSEL (1962) recognized this population as an infrasubspecific “natio”. KOLI (1969) denied the distinction of *ferrugineus* from *gobio* without stating what material had been studied, and BIANCO (1995b) negated its morphological differentiation without providing details too. KOTTELAT (1997) considered the taxonomy of Italian sculpins unresolved. To us this discussion seems rather inconclusive too, because no author has compared population series of *ferrugineus* with samples from geographically adjacent populations of uncontested *C. gobio*. This comparison is deemed crucial, however, because many morphometric and meristic characters of sculpins appear to be distributed in a rather mo-

saic-like pattern at the scale of geographical regions or of single streams. The genetic studies of *C. gobio* have added additional characters to discriminate sometimes fairly deep lineages in various parts of Europe, but a range-wide study of these characters either at the anatomical or at the molecular levels is unavailable. In our eyes, this state of knowledge renders any attempts for microtaxonomic revision premature. The allozyme distance between sculpins from the Brenta river, which originated from the range of *ferrugineus*, and Danubian population samples does not support the notion of taxonomic distinction on the species level, because the genus *Cottus* contains more deeply subdivided stocks in other areas of Europe that have never been distinguished by taxonomy. However, the evolution of the body shape and the body size can proceed independently from, and faster than allozyme substitution if, as it is indeed observed for the regional population groups of *Cottus gobio*, different alleles are not just distinguished by frequency but have reached complete fixation in various population groups (RIFFEL & SCHREIBER 1995). One may easily conceive a recent range expansion into sub-Mediterranean Italy, which was accompanied by the transformation of a smaller phenotype, rather than by evolution at the biochemical-genetic level. By contrast, the long-standing occurrence of sculpins at least in certain core areas of Central and north Europe, augmented by effects of range dynamics (THIENEMANN 1941, 1950) evidently permitted the evolution of deep genotypic lineages, whereas the phenotypes remained largely conserved. Only a closer look reveals a local or regional variance in meristic counts, proportions of body shape, and body size (RIFFEL & SCHREIBER 1998). If the evolution of *Cottus* implies a certain degree of decouplement among molecular substitution and relative morphological stasis indeed, it only resembles the equivalent discordance of enzymes and morphs in other ancient phylogenetic lineages (SCHREIBER et al. 1992, 1996, 1999).

At present we do not suggest to synonymize the taxon *ferrugineus* with *gobio*, pending a more comprehensive analysis in terms of character breadth and the density of geographical sampling. We propose to test if a smaller body size and distinctive anal fin ray counts characterize every sculpin population from the range of the debated taxon *ferrugineus*, and if these characters are susceptible to environmental modification (body length). Of interest, *Cottus petiti* (Băcescu & Băcescu-Mester, 1964) from southern France represents another small-bodied, and narrowly endemic taxon from the southern fringe of the range of *Cottus gobio*. *Cottus petiti* is restricted to the Lez river near Montpellier and, according to a specimen in the Staatliches Museum für Naturkunde (Stuttgart) also occurs in the Gardon de St. Jean, near Nîmes (R. FRICKE, pers. comm.). Being distinguished by body size and certain discriminatory features of its outward appearance, its validity as a species remains controversial (BĂCESCU & BĂCESCU-MESTER 1964, KOTTELAT 1997). At the allozyme level *C. petiti* is hardly distinguished from *C. gobio* samples collected in other French rivers, at least not more clearly so than several samples of the latter proved to differ among each other (EPPE et al. 1999). Specimens compiled from scattered localities spread across Europe might provide a rather poorly suited material for inferring the taxonomic validity of southern, dwarfed sculpins, because the spatial scaling of population differentiation is to be understood by the dense sampling of geographically adjacent population samples. The absence of a biochemical taxon marker in an otherwise deeply dissected species gene pool does not necessarily negate a valid subspecies status of a geographical population if this could be recognized reliably by heritable morphometrics.

5 References

- BĂCESCU, M. & BĂCESCU-MESTER, L. (1964): *Cottus petiti* sp. n.; un chabot nouveau recolté en France. Considérations zoogéographiques et données comparatives sur d'autres *Cottus* d'Europe. – *Vie et Milieu* 17 (Supplement): 31–448.
- BANARESCU, P. (1963): Date biometrică și sistematică asupra genului *Cottus* (Pisces, Cottidae). – *Societatea de Științe naturale și geografie din Republica socialistă România, Comunicari de Zoologie* 2: 119–135.
- BANARESCU, P. (1992): Zoogeography of fresh waters. – Vol. 2: Distribution and dispersal of freshwater animals in North America and Eurasia, pp. 520–1091; Wiesbaden (Aula-Verlag).
- BARANDUN, J. (1990): Auswirkungen von Ausbreitungsbarrieren auf das Verhalten von Groppen (*Cottus gobio* L.). Anregungen für den Artenschutz. – *Natur und Landschaft* 65/2: 66–68.
- BERG, L. S. (1932): Übersicht der Verbreitung der Süßwasserfische Europas. – *Zoogeographia* 1: 107–208.
- BIANCO, P. G. (1990): Potential role of the palaeohistory of the Mediterranean and Paratethys basins for the early dispersal of Euro-Mediterranean freshwater fishes. – *Ichthyological Exploration of Freshwaters* 1: 167–184.
- BIANCO, P. G. (1994): L'ittiofauna continentale dell'Appennino umbro-marchigiano, barriera semipermeabile allo scambio di componenti primarie tra gli opposti versanti dell'Italia centrale. – *Biogeographia* 17: 427–485.
- BIANCO, P. G. (1995a): Mediterranean endemic freshwater fishes in Italy. – *Biological Conservation* 72: 159–170.
- BIANCO, P. G. (1995b): Factors affecting the distribution of freshwater fishes especially in Italy. – *Cybium* 19: 241–259.
- BLESS, R. (1990): Die Bedeutung von gewässerbaulichen Hindernissen im Raum-Zeit-System der Groppe (*Cottus gobio* L.). – *Natur und Landschaft* 65: 581–585.
- BONAPARTE, C. L. (1846): Catalogo metodico dei pesci Europei. – *Atti della settima Adunanza degli Scienziati italiani in Napoli (1845)*, pp. 1–95; Naples.
- DOWNHOWER, J. F., LEJEUNE, P., GAUDIN, P. & BROWN, L. (1990): Movements of the chabot (*Cottus gobio*) in a small stream. – *Polskie Archiwum Hydrobiologii* 37: 119–126.
- ENGLBRECHT, C. C., FREYHOF, J., NOLTE, A., RASSMANN, K., SCHLIEWEN, U. & TAUTZ, D. (2000): Phylogeography of the bullhead *Cottus gobio* (Pisces: Teleostei: Cottidae) suggests a pre-Pleistocene origin of the major central European populations. – *Molecular Ecology* 9: 709–722.
- EPPE, R., PERSAT, H., BEAUDOU, B. & BERREBI, P. (1999): Genetic variability in sculpins (genus *Cottus*) from southern France, with reference to the taxonomic status of an endemic species, *C. petiti*. – *Heredity* 83: 533–540.
- GANDOLFI, G., ZERUNIAN, S., TORRICELLI, P. & MARCONATO, A. (1991): I pesci delle acque interne italiane, 616 pp.; Rome (Istituto poligrafico e zecca dello Stato, Ministero dell'Ambiente, Unione zoologica italiana).
- HÄNFLING, B. (1997): Genetische Differenzierung von Populationen von Döbel und Mühlkoppe in den nordostbayerischen Einzugsgebieten von Rhein, Donau und Elbe. – In: SCHREIBER, A. & LEHMANN, J. (eds.): *Populationsgenetik im Artenschutz*, pp. 61–76; Münster (Landwirtschaftsverlag).
- HÄNFLING, B. & BRANDL, R. (1998): Genetic differentiation of the bullhead *Cottus gobio* L. across watersheds in Central Europe: evidence for two taxa. – *Heredity* 80: 110–117.
- HÄNFLING, B., HELLEMANS, B., VOLCKAERT, F. A. M. & CARVALHO, G. R. (2002): Late glacial history of the cold-adapted freshwater fish *Cottus gobio*, revealed by microsatellites. – *Molecular Ecology* 11: 1717–1729.
- HECKEL, J. & KNER, R. (1858): *Die Süßwasserfische der österreichischen Monarchie mit Rücksicht auf die angränzenden Länder*, XII + 388 pp.; Leipzig (Wilhelm Engelmann).
- KOLI, L. (1969): Geographical variation of *Cottus gobio* L. (Pisces, Cottidae) in Northern Europe. – *Annales zoologici fennici* 6: 353–390.
- KONTULA, T. (2003): Phylogeography and evolution of freshwater cottid fishes. PhD Thesis, Finnish Museum of Natural History and University of Helsinki, Finland, 21 pp.
- KONTULA, T. & VÄINÖLÄ, R. (2001): Postglacial colonization of Northern Europe by distinct

- phylogeographic lineages of the bullhead, *Cottus gobio*. – *Molecular Ecology* **10**: 1983–2002.
- KONTULA, T. & VÄINÖLÄ, R. (2004): Molecular and morphological analysis of secondary contact zones of *Cottus gobio* in Fennoscandia: Geographical discordance of character transition. – *Biological Journal of the Linnean Society* **81**: 535–552.
- KOTTELAT, M. (1997): European freshwater fishes. – *Biologia (Bratislava)* **52** (Supplement 5): 1–271.
- OLIVA, O. & HENSEL, K. (1962): Studies of sculpins (*Cottus gobio* L.) from the river Pruth. – *Vestník československe zoologicke Spolecnosti* **26**: 244–249.
- PAŠKO, Ľ. & MAŠLAK, R. (2003): Genetics of the peripheral populations of the Alpine bullhead, *Cottus poecilopus* (Scorpaeniformes, Cottidae), in Poland. – *Journal of zoological Systematics and Evolutionary Research* **41**: 196–204.
- RIFFEL, M. & SCHREIBER, A. (1995): Coarse-grained population structure in Central European sculpin (*Cottus gobio* L.): Secondary contact or ongoing genetic drift? – *Journal of zoological Systematics and Evolutionary Research* **33**: 173–184.
- RIFFEL, M. & SCHREIBER, A. (1998): Morphometric differentiation in populations of the Central European sculpin *Cottus gobio* L., a fish with deeply divergent genetic lineages. – *Canadian Journal of Zoology* **76**: 876–885.
- SCHREIBER, A., EISINGER, M. & STORCH, V. (1996): Allozymes characterize sibling species of bipolar Priapulida (*Priapulus*, *Priapulopsis*). – *Polar Biology* **16**: 521–526.
- SCHREIBER, A., SEIBOLD, I., NÖTZOLD, G. & WINK, M. (1999): Cytochrome b gene sequence haplotypes characterize chromosomal lineages of anoa (Bovidae: *Bubalus* spec.), the Sulawesi dwarf buffalo. – *Journal of Heredity* **90**: 165–176.
- SCHREIBER, A., SVAVARSSON, J. & STORCH, V. (1992): Blood proteins in bipolar Priapulida. – *Polar Biology* **12**: 667–672.
- SHAKLEE, J. B., ALLENDORF, F. W., MORIZOT, D. C. & WHITT, G. S. (1990): Gene nomenclature for protein-coding loci in fish. – *Transactions of the American Fisheries Society* **119**: 2–15.
- SKOŘEPA, V. (1966): Zur Systematik der Böhmisches West-Groppen (*Cottus gobio* L.) (Cottidae, Osteichthyes). – *Acta Societatis zoologicae bohemoslovaca* **31**: 260–273.
- SMYLY, W. J. P. (1957): The life history of the bullhead or miller's thumb (*Cottus gobio*). – *Proceedings of the zoological Society of London* **138**: 431–453.
- STAHLBERG-MEINHARDT, S. (1994): Verteilung, Habitatansprüche und Bewegungen von Mühlkoppe (*Cottus gobio* Linnaeus, 1758) und Bachforelle (*Salmo trutta* Linnaeus, 1758) in zwei unterschiedlich anthropogen beeinflussten Fließgewässern in Vorharz. – *Hefte des Instituts für Wasserwirtschaft, Hydrologie und landwirtschaftlichen Wasserbau der Universität Hannover* **80**: 1–197.
- THIENEMANN, A. (1941): Die Süßwasserfische Deutschlands. Eine tiergeographische Skizze. – In: DEMOLL, R. & MAIER, H. N. (eds.): *Handbuch der Binnenfischerei Mitteleuropas III A*, pp. 1–32; Stuttgart (Schweizerbart).
- THIENEMANN, A. (1950): Verbreitungsgeschichte der Süßwassertierwelt Europas, XVI + 809 pp.; Stuttgart (Schweizerbart).
- TORKE, W. (1998): Fische aus jungpleistozänen und holozänen Siedlungsplätzen in Baden-Württemberg. – *Jahreshefte der Gesellschaft für Naturkunde in Württemberg* **154**: 231–259.
- VOLCKAERT, F. A. M., HÄNFLING, B., HELLEMANS, B. & CARVALHO, G. R. (2002): Timing of the population dynamics of bullhead *Cottus gobio* (Teleostei: Cottidae) during the Pleistocene. – *Journal of Evolutionary Biology* **15**: 930–944.
- WITKOWSKI, A. (1979): A taxonomic study on freshwater sculpins of genus *Cottus* Linnaeus, 1758 (*Cottus gobio* L. and *Cottus poecilopus* Heck.) in Poland. – *Acta Universitatis Wratislaviensis, Prace Zoologiczne* **10**: 1–95.

Authors' addresses:

LAURA PAPA¹ & PD Dr. ARND SCHREIBER, Forschungszentrum Umwelt der Universität Karlsruhe, Adenauerring 20, 76131 Karlsruhe, Germany;
e-mail: schreiber@fzu.uni-karlsruhe.de

¹ Current address: LAURA PAPA, Institut für Zoologie, Universität Heidelberg, Im Neuenheimer Feld 230, 69120 Heidelberg, Germany; e-mail: papa@eco.uni-heidelberg.de

Manuscript received: 18.X.2004, accepted: 14.II.2005.

ISSN 0341-0145

Autoren-Richtlinien: <http://www.naturkundemuseum-bw.de/stuttgart/schriften>
Schriftleitung: Dr. Hans-Peter Tschornig, Rosenstein 1, 70191 Stuttgart
Gesamtherstellung: Gulde-Druck, 72072 Tübingen